

Datasheet

XuanTie C910

High-Performance AP



Overview

C910 is a RISC-V compatible 64-bit high performance processor developed by C-SKY MicroSystems Co., Ltd. It delivers industry-leading performance in control flow, computing and frequency through architecture and micro-architecture innovations. The C910 processor is based on the RV64GC instruction set and implements the XIE (XuanTie Instruction Extension) technology. C910 adopts a state of the art 12 stages out-of-order multiple issue superscalar pipeline with high frequency, IPC, and power efficiency. C910 supports hardware cache coherency. Each cluster contains 1-4 cores. The C910 supports the AXI4 bus interface and includes a device coherence port. The C910 uses the Sv39 virtual address system with XMAE (XuanTie Memory Attributes Extension) technology. In addition, C910 includes the standard CLINT and PLIC interrupt controllers and supports RV-compatible debug interface and performance monitors.

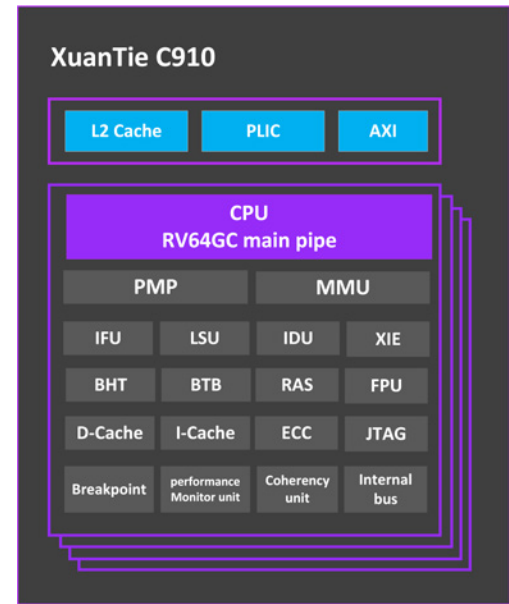

Features

Feature	Description
Architecture	RV64GC
SMP	Up to 4 cores in each cluster
Pipeline	12 stages (Integer)
Floating-point Unit	Support RISC-V F, D instruction extension Support IEEE 754-2008 standard
Bus interface	AXI4-128 master
Device coherence port	AXI4-128 slave (Optional)
Instruction Cache	Up to 64KB with optional parity
Data Cache	Up to 64KB with optional ECC

Feature	Description
L2 Cache	Up to 8MB with optional ECC Supporting parallel access with multi-bank
XuanTie extensions	XuanTie Instruction Extension (XIE) XuanTie Memory Attributes Extension (XMAE)
Memory Management Unit (MMU)	Sv39 virtual memory translation Up to 2048 entry TLB
PMP	Up to 16 regions
Interrupt Controller	Flexibly configurable Platform-Level Interrupt Controller (PLIC) for supporting wide range of system event scenarios

XuanTie C910 Components

• Processor Overview

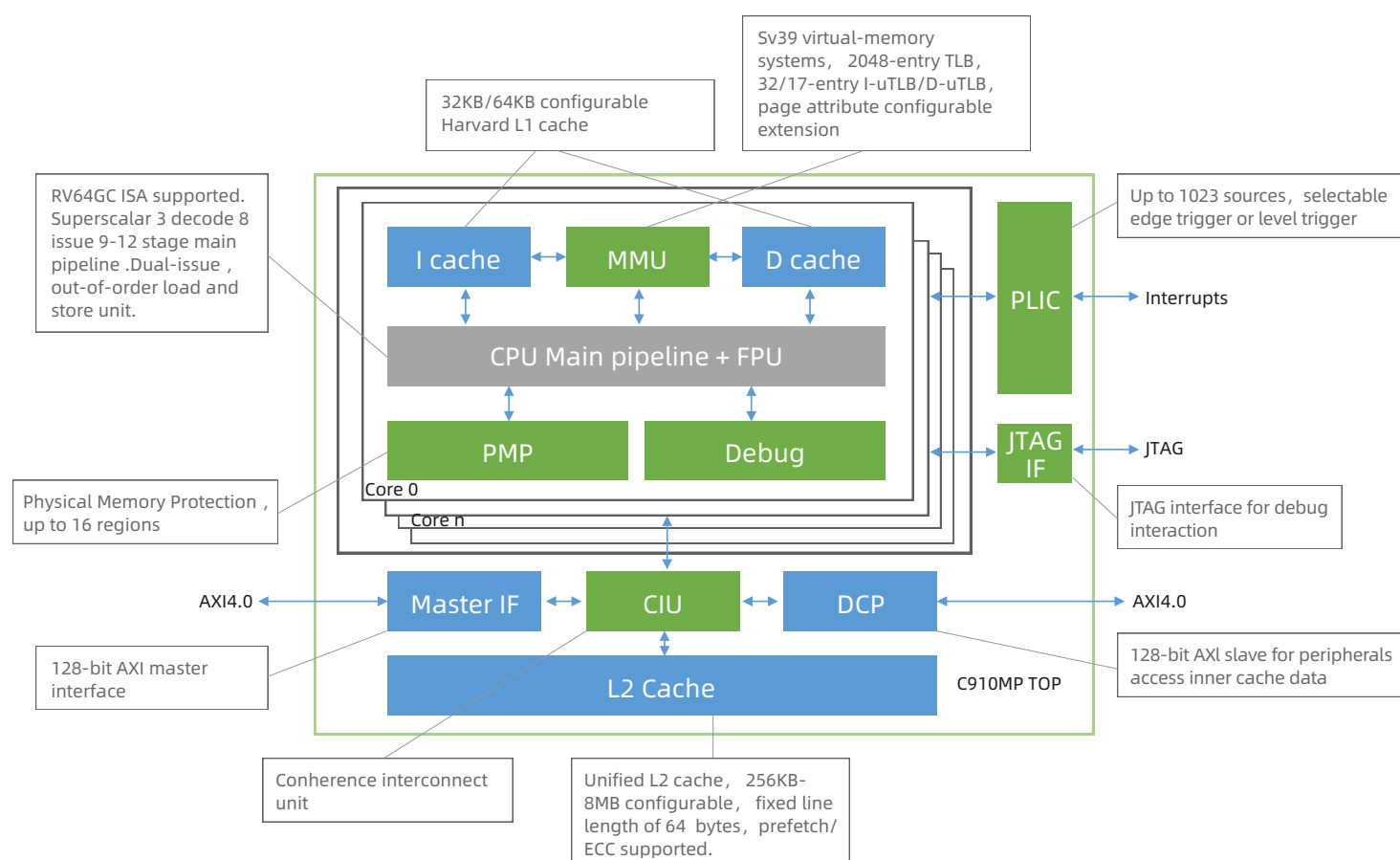

• Multi-Core

- ◇ Support 2-4 core homogeneous multi-core system.
- ◇ MOESI coherency protocol.
- ◇ 2-way centralized snoop buffer.
- ◇ Exclusive memory access instructions.
- ◇ Integrates multi-core interrupt controllers, timers, and debuggers.

• Memory sub-system

The C910 has 32K / 64K instruction and data cache with cache coherency support. Hardware cache coherency ensures the consistency of all caches efficiently. The shared L2-Cache, which is up to 8 MB, supports ECC and parity check. Software and hardware collaborative optimization of data consistency between TLB, I-Cache and D-Cache.

- ◇ **The L1 instruction memory system has the following key features:**
 - VIPT, two-way set-associative instruction cache.
 - Fixed cache line length of 64 bytes.
 - 128-bit read interface from the L2 memory system.
- ◇ **The L1 data memory system has the following features:**
 - PIPT, two-way set associative L1 data cache.
 - Fixed cache line length of 64 bytes.
 - 128-bit read interface from the L2 memory system.
 - Up to 128-bit read data paths from the data L1 memory system to the data path.
 - Up to 128-bit write data path from the data path to the L1 memory system.
- ◇ **The L2 Cache has the following features:**
 - Configurable size of 256KB, 512KB, 1MB, 2MB, 4MB, or 8MB.
 - PIPT, 16-way set-associative structure.
 - Fixed line length of 64 bytes.
 - Optional ECC protection.
 - Support data prefetch.

• Memory Management Unit (MMU)

- ◇ Sv39 virtual memory systems supported.
- ◇ 32/17-entry fully associative I-uTLB/D-uTLB.
- ◇ 2048-entry 4-way set-associative shared TLB.
- ◇ Hardware page table walker.
- ◇ Virtual memory support for full address space and easy hardware for fast address translation.
- ◇ Code/data sharing.
- ◇ Support for full-featured OS such as Linux.
- ◇ XMAE (XuanTie Memory Attributes Extension) technology extends page table entries for additional attributes.

• Physical Memory Protection (PMP)

16 regions basic read/write/execute memory protection with low cost.

• Performance Monitor Unit (PMU)

Program code performance tuning.

• Platform-Level Interrupt Controller (PLIC)

- ◇ Support multi-core interrupt control.
- ◇ Up to 1023 PLIC interrupt sources.
- ◇ Up to 32 PLIC interrupt priority levels.
- ◇ Up to 8 PLIC interrupt targets.
- ◇ Selectable edge trigger or level trigger.

• JTAG Debug

- ◇ Support multi-core debug.
- ◇ JTAG debug interface support several triggers.
- ◇ Support software breakpoints.
- ◇ Check and modify CPU register resource.
- ◇ Single step or multi step flexibly supported.
- ◇ High speed program download through JTAG.

• Float Point Unit (FPU)

- ◇ RISC-V F and D extensions
- ◇ Support half/single/double precision
- ◇ Fully IEEE-754 compliant.
- ◇ Does not generate floating-point exceptions.
- ◇ User configurable rounding modes.

• Branch Predictor

- ◇ Branch Target Buffer (BTB) and Branch History Table (BHT) to speed up control codes
- ◇ Return Address Stack (RAS) to speed up procedure returns
- ◇ Loop buffer to speed up short loops

• RV Compatibility with Custom Extensions

The C910 is fully compatible with the RV64GC instruction set and supports the standard M/S/U privilege program model. The C910 includes a standard 8-16 region PMP and Sv39 MMU, which is fully compatible with RISC-V Linux. The C910 includes standard CLINT and PLIC interrupt controllers, RV compatible PMU and debug interface.

• RV Compatibility

Component	RV version
ISA	RV64GC
Privilege	1.10
MMU	Sv39
Interrupt controller	CLINT/PLIC

• Interfaces

- ◇ Master AXI (M-AXI)
- ◇ DCP (S-AXI)
- ◇ Debug (JTAG)
- ◇ Interrupts
- ◇ Low power control

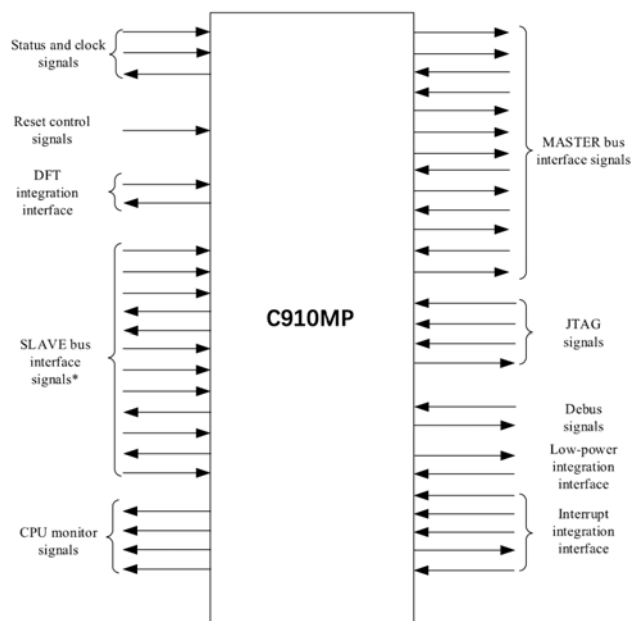

PPA

Performance	5.8 DMIPS/Mhz (O2) 6.96 Coremark/Mhz (O3)
Frequency	2.0 ¹ ~ 2.5 ² GHz (Typical)
Area	1.137 (MP2) / 0.398 (core)
Power	~ 200 uW/MHz per core

1.TSMC 12nm, std lvt, mem ultv, 6T Turbo lib, 0.8v;
 2.TSMC 12nm, std 30% ulvt, mem ultv, 6T Turbo lib, 1.0v;
 Dynamic power@tt85c, Frequency@tt85c;
 Configuration: MP2 32K L1\$, 256K L2\$, FP, full ECC.

Configurations

Config	Options
Core Number	1-4
L1 D-Cache Size	32K, 64K
L1 I-Cache Size	32K, 64K
L2-Cache Size	256K, 512K, 1M, 2M, 4M, 8M
DCP	Present or not

Software Ecosystems

- ◇ Compiler, assembler, linker, debugger and binary tools are contributed to GNU and supported officially.
- ◇ Linux kernel is contributed to Linux foundation and supported officially.
- ◇ QEMU is contributed and supported officially.
- ◇ C-SKY Integrated Development Environment (CDS), compatible with Eclipse development.
- ◇ Graphical profiling and statistical analysis tools base trace data (simulator) .
- ◇ ICE, CK-Link Pro, high speed (1.1Mbytes/s) JTAG debug hardware.
- ◇ Multi-core JTAG online debug.

Linux System

C910 supports the official RISC-V Linux and its software applications ecosystem. e.g.: GNU toolchain, Fedora, Debian, buildroot and thousands of open source software based on Linux. XuanTie CPU will continue to make contributions to RISC-V architecture porting in Linux ecosystem.